



© 2008 Mazda Motor of America, Inc.

Subject: SQUEAKING NOISE AROUND REAR CENTER CONSOLE LID	Bulletin No: 09-040/08
	Last Issued: 12/12/2008

BULLETIN NOTE

This bulletin supersedes the previous bulletin 09-026/06, issued 6/27/2006. The APPLICABLE MODEL(S)/VINS, DESCRIPTION, REPAIR PROCEDURE, PART(S) INFORMATION and WARRANTY INFORMATION sections have been revised.

APPLICABLE MODEL(S)/VINS

2006 MX-5 vehicles with VINs lower than JM1 NC**** ** 131997 (produced before November 27, 2006)

DESCRIPTION

Some vehicles may exhibit a squeaking noise from around the rear center console lid area when driving on a rough road or turning corners at slow speeds. The following may cause the noise:

- Torque of the rear center console lid striker screw is insufficient. As a mass-production change, the tightening process has been revised in production.
- The fastener comes in contact with the body. As a mass-production change, the fastener has been eliminated.

Customers having this concern should have their vehicle repaired using the following repair procedure.

REPAIR PROCEDURE

On 2006 MX-5 vehicles with VINs lower than JM1 NC**** ** 118186 (produced before May 10, 2006) perform the following repair procedure:

- A - TIGHTEN STRIKER SCREWS
- B - REMOVE FASTENERS AND INSTALL FOAM PADS

On 2006 MX-5 vehicles with VINs JM1 NC**** ** 118187 through 131997 (produced before November 27, 2006) perform the following repair procedure:

- B - REMOVE FASTENERS AND INSTALL FOAM PADS

CONSUMER NOTICE: The information and instructions in this bulletin are intended for use by skilled technicians. Mazda technicians utilize the proper tools/equipment and take training to correctly and safely maintain Mazda vehicles. These instructions should not be performed by "do-it-yourselfers." Customers should not assume this bulletin applies to their vehicle or that their vehicle will develop the described concern. To determine if the information applies, customers should contact their nearest authorized Mazda dealership. Mazda North American Operations reserves the right to alter the specifications and contents of this bulletin without obligation or advance notice. All rights reserved. No part of this bulletin may be reproduced in any form or by any means, electronic or mechanical---including photocopying and recording and the use of any kind of information storage and retrieval system ---without permission in writing.

A - TIGHTEN STRIKER SCREWS

1. Verify customer concern.
2. Open the center rear console lid and grasp the striker to verify if there is any movement of the striker.
 - If there is movement, go to STEP 3.
 - If there is no movement, continue to diagnose source of squeak.

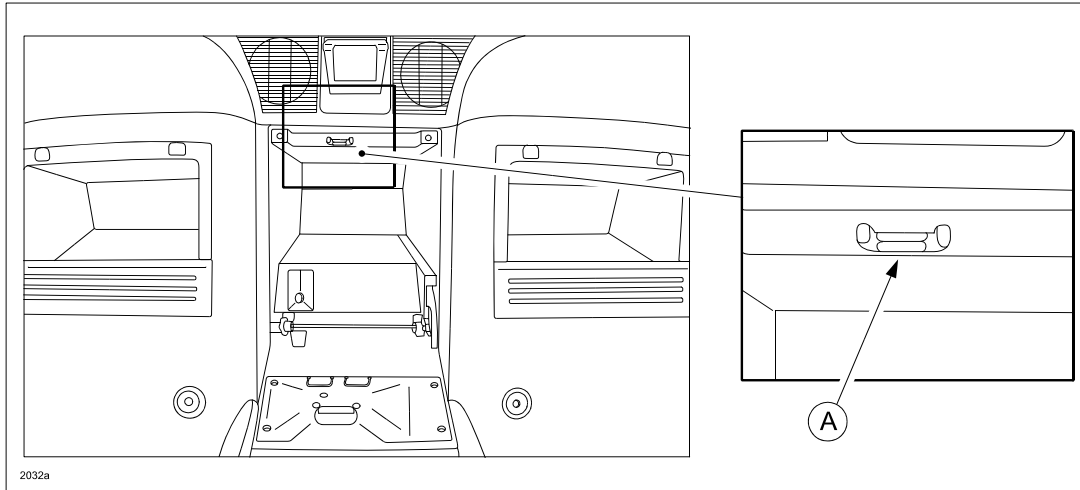

3. Remove the back trim. Refer to Workshop Manual section 09-17 BACK TRIM REMOVAL / INSTALLATION.
4. Tighten the 3 screws attaching the striker to the back trim.

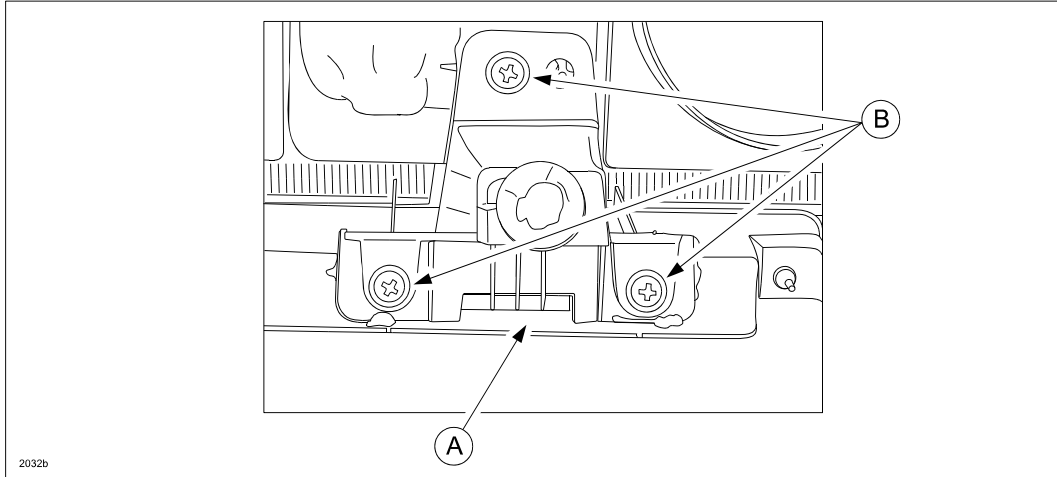

5. Proceed to B - INSTALL FOAM PADS.

B - REMOVE FASTENERS AND INSTALL FOAM PADS

1. Verify customer concern.
2. If not previously removed in repair procedure A, remove the back trim. Refer to Workshop Manual section 09-17 BACK TRIM REMOVAL / INSTALLATION.

- Remove the fastener located on the striker.

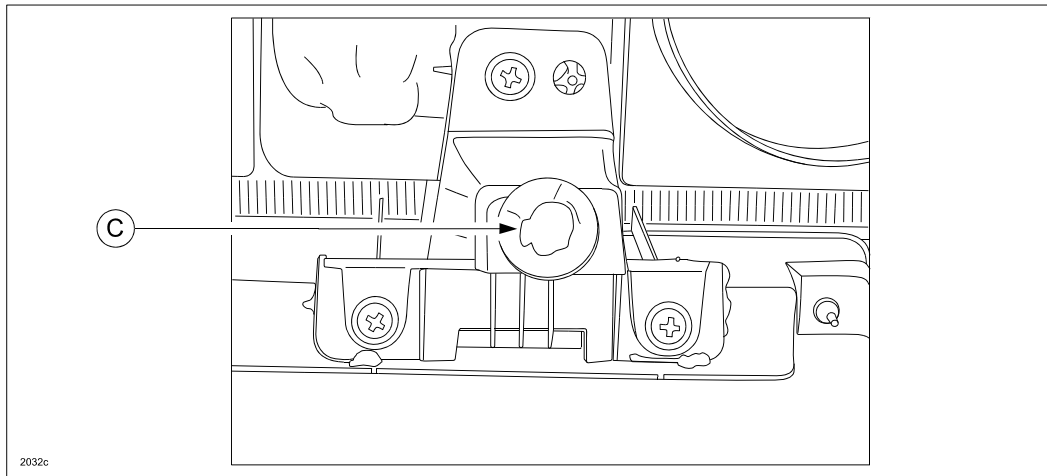

- Using a 3.0 mm-thick urethane foam pad from noise parts set TA01-76-100, cut 2 pieces 20 mm x 13 mm.
- Remove the tape backing and attach the pads on top of each other where the fastener was previously located.

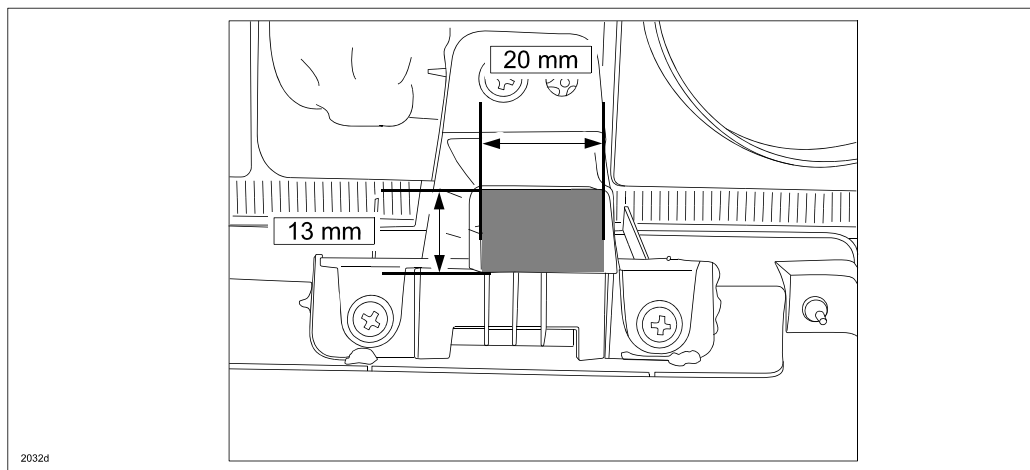

- Install the back trim. Refer to Workshop Manual section 09-17 BACK TRIM REMOVAL / INSTALLATION.
- Verify repair.

PART(S) INFORMATION

Part Number	Description	Qty.	Notes
TA01-76-100	Noise Parts Set	1	Use 3.0 mm-thick urethane pad. (Approx. 21 vehicles can be repaired with one sheet of this urethane pad.)

WARRANTY INFORMATION

NOTE:

- This warranty information applies only to verified customer complaints on vehicles eligible for warranty repair.
- This repair will be covered under Mazda's New Vehicle Limited Warranty term.
- Additional diagnostic time cannot be claimed for this repair.

Warranty Type	A
Symptom Code	82
Damage Code	9J
Part Number Main Cause	7777-SP-D0W
Quantity	1
Operation Number / Labor Hours:	XXB349RX / 0.6 Hrs