

# Technical Service Bulletin

Mazda North American Operations  
Irvine, CA 92618-2922



<b>Subject:</b> <b>AIR CONDITIONER DOES NOT BLOW COLD AIR DUE TO CRACKED COOLER PIPE (HI) A (REFRIGERANT LEAK)</b>	<b>Bulletin No.:</b> 07-002/21
	<b>Last Issued:</b> 02/01/2021

## BULLETIN NOTES

This bulletin supersedes the previously issued bulletin(s) listed below. The changes are noted in Red.

Previously issued TSBs:	Date(s) issued:
07-004/18	08/01/18
07-004/1807-004/18	05/18/18
07-004/18	05/10/18

## APPLICABLE MODEL(S)/VINS

2016-2020 MX-5 with VINs lower than JM1ND\*\*\*\*\*418386 (built before Sep. 10, 2020)

## DESCRIPTION

Some vehicles may experience that the A/C does not blow cold air (blows warm air) due to a refrigerant leak. This is caused by a crack in the cooler pipe (HI) A (1) due to engine vibration. To correct this issue, the material and thickness of the cooler pipe (HI) A has been changed to increase durability (pipe diameter has been changed from 12mm to 16mm).

**CONSUMER NOTICE:** The information and instructions in this bulletin are intended for use by skilled technicians. Mazda technicians utilize the proper tools/equipment and take training to correctly and safely maintain Mazda vehicles. These instructions should not be performed by "do-it-yourselfers." Customers should not assume this bulletin applies to their vehicle or that their vehicle will develop the described concern. To determine if the information applies, customers should contact their nearest authorized Mazda dealership. Mazda North American Operations reserves the right to alter the specifications and contents of this bulletin without obligation or advance notice. All rights reserved. No part of this bulletin may be reproduced in any form or by any means, electronic or mechanical---including photocopying and recording and the use of any kind of information storage and retrieval system ---without permission in writing.

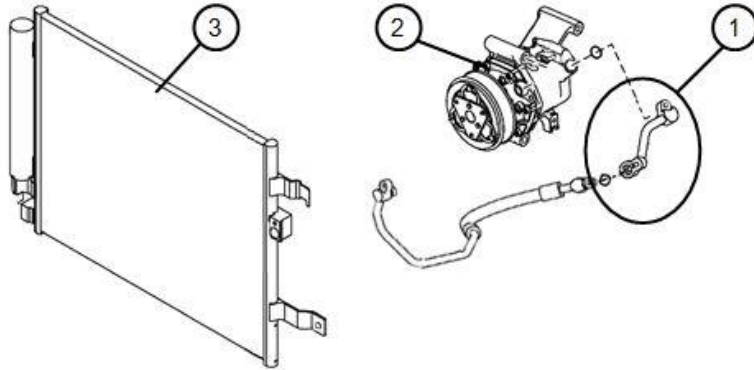

(1)	Cooler pipe (HI) A
(2)	A/C compressor
(3)	Condenser

Location of cracking



Customers having this concern should have their vehicle repaired using the following repair procedure.

### REPAIR PROCEDURE

1. Verify customer concern.
2. Inspect the cooler pipe (HI) A.

**CONSUMER NOTICE:** The information and instructions in this bulletin are intended for use by skilled technicians. Mazda technicians utilize the proper tools/equipment and take training to correctly and safely maintain Mazda vehicles. These instructions should not be performed by "do-it-yourselfers." Customers should not assume this bulletin applies to their vehicle or that their vehicle will develop the described concern. To determine if the information applies, customers should contact their nearest authorized Mazda dealership. Mazda North American Operations reserves the right to alter the specifications and contents of this bulletin without obligation or advance notice. All rights reserved. No part of this bulletin may be reproduced in any form or by any means, electronic or mechanical---including photocopying and recording and the use of any kind of information storage and retrieval system ---without permission in writing.

- If the cooler pipe (HI) A is cracked, replace the cooler pipe (HI) A with a modified one according to the instructions on MGSS (REFRIGERANT LINE REMOVAL/INSTALLATION).
- If the cooler pipe (HI) A is not cracked, this TSB is not applicable. Refer to troubleshooting procedure on MGSS (NO COOL AIR [CLIMATE CONTROL SYSTEM]).

3. Verify repair.

## PARTS INFORMATION

Part Number	Description	Qty.	Notes
NA6W-61-466B	Cooler pipe (HI) A	1	Includes 1 O-ring (S33P-61-J17)
S33P-61-J17	O-Ring	1	[R] Replacement Part
5555-FG-002	A/C Refrigerant	As required	

**NOTE:** Two O-rings (S33P-61-J17) are required for repair.

## WARRANTY INFORMATION

### NOTE:

- This warranty information applies only to verified customer complaints on vehicles eligible for warranty repair.
- This repair will be covered under Mazda's New Vehicle Limited Warranty.
- Additional diagnostic time cannot be claimed for this repair.

Warranty Type	A
Symptom Code	59
Damage Code	9A
Part Number Main Cause	NA6W-61-466B
Quantity	1
Operation Number / Labor Hours:	XXP3RARX / 1.2 Hrs. Includes: Cooler pipe (HI) A replacement and refrigerant recharge

**CONSUMER NOTICE:** The information and instructions in this bulletin are intended for use by skilled technicians. Mazda technicians utilize the proper tools/equipment and take training to correctly and safely maintain Mazda vehicles. These instructions should not be performed by "do-it-yourselfers." Customers should not assume this bulletin applies to their vehicle or that their vehicle will develop the described concern. To determine if the information applies, customers should contact their nearest authorized Mazda dealership. Mazda North American Operations reserves the right to alter the specifications and contents of this bulletin without obligation or advance notice. All rights reserved. No part of this bulletin may be reproduced in any form or by any means, electronic or mechanical---including photocopying and recording and the use of any kind of information storage and retrieval system ---without permission in writing.